

CONTENTS

- 1 Cutting Board Mount
- 4 Sleeve Nuts
- 4 Flat Head Screws

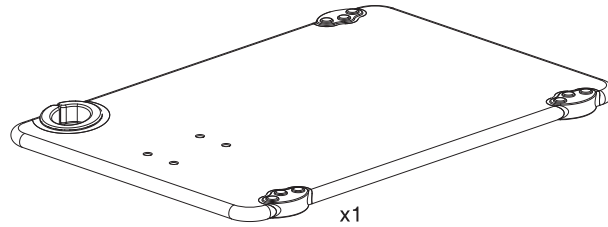

*Contents are not to scale to each other

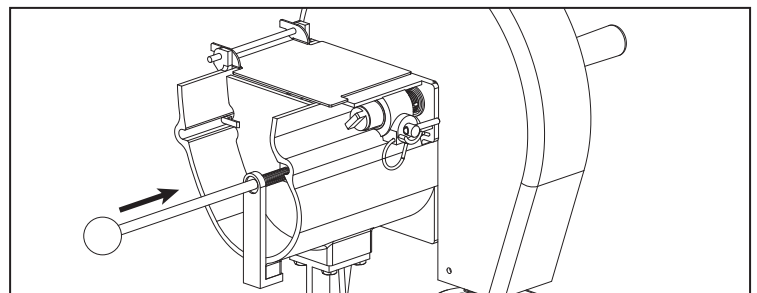
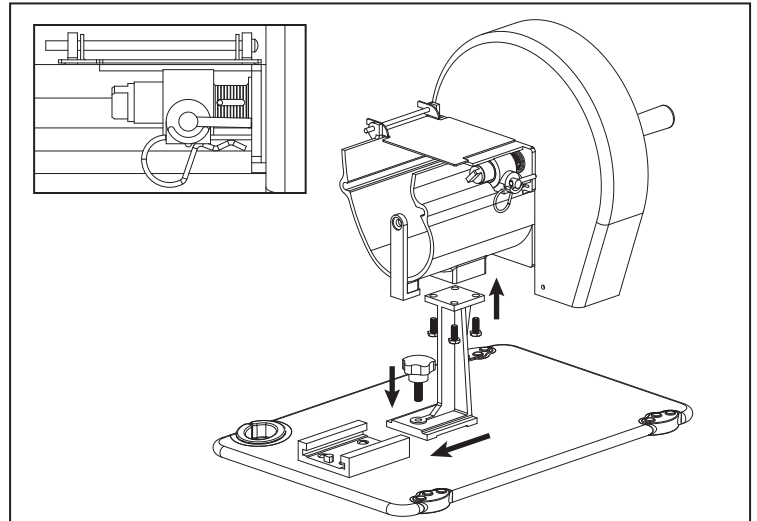
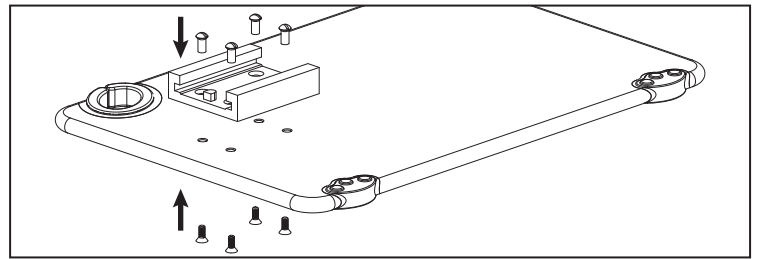
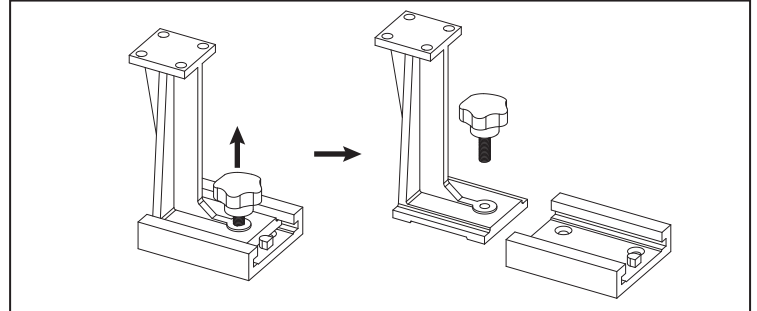
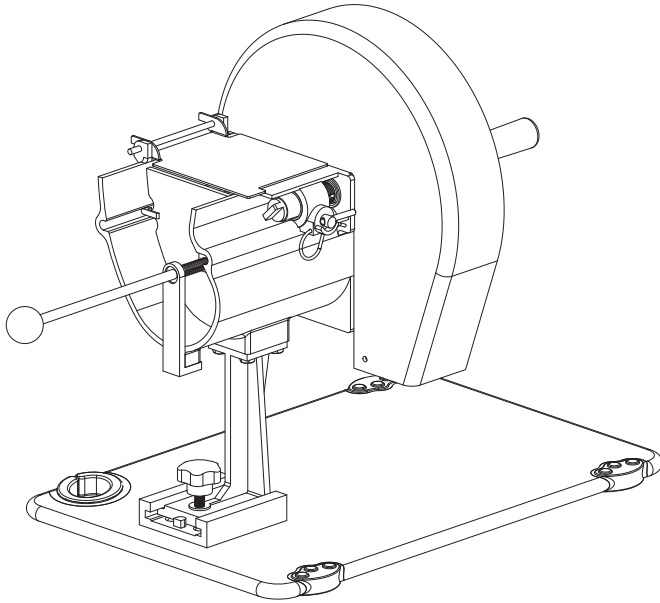

**WARNING: THE BLADES ARE VERY SHARP.
PLEASE USE CAUTION WHEN HANDLING.**

- 1** Remove the mounting locking screw and slide out leg from the mounting base.
- 2** Attach the mounting base to the cutting board mount with the flat head screws and sleeve nuts provided with the cutting board mount.
- 3** Attach the mounting leg to the fruit and vegetable slicer with hex screws.

Note: The locking pin should be in the 9 o'clock position on the fruit and vegetable slicer.

- 4** Slide the assembled fruit and vegetable slicer onto the mounting base and secure with the mounting locking screw.
- 5** Place the push plate inside fruit and vegetable slicer. Slide the push rod through the "L" bracket hole and through the spring and thread into the back of the push plate.